

Ordering information:
 GD-PJS-3229A
 (1) (2) (3) (4) (5) (6) (7)
 (1):Series No.
 (2):Schematic option:R
 (3):Material of housing:
 PB=PBT, 9T=PA9T, 10=PA10T
 (4):Housing color:
 0A=Black
 (5):Terminal plating:
 △2 B=15u'' gold plating on mating area,
 70u'' Ni under plating,
 for contact 1 2 3 5 6 7 8 9 10 11,
 100u'' tin on solder tail
 for contact 4, Gold Flash on solder tail.
 (6):Special option:
 00=No special option
 (7):Packing mode:
 1=Reel packing

SCHEMATIC

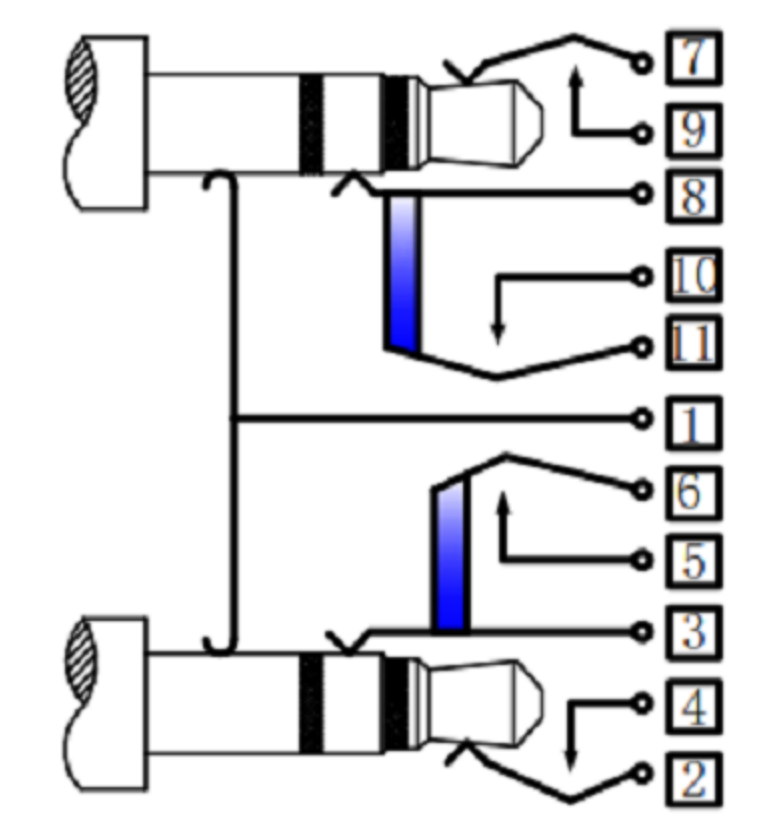
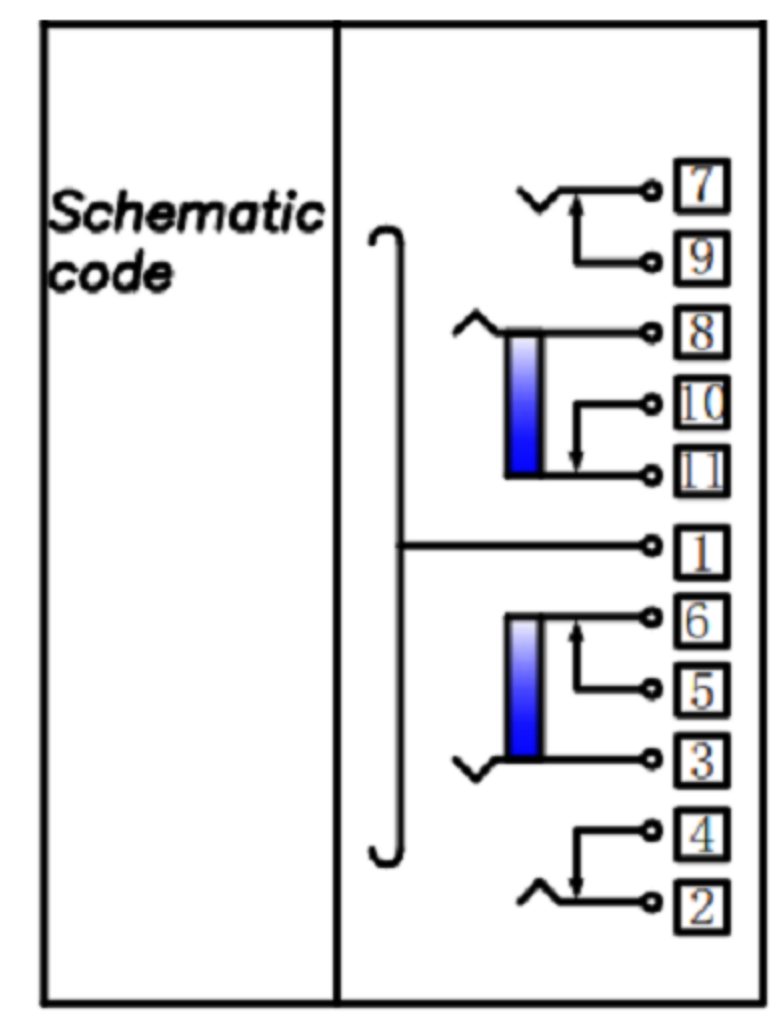

PLUG inserted

Specification:
 1. Rating : DC 30V 0.5A;
 2. Contact resistance: ≤30mΩ;
 After test: ≤50mΩ
 3. Insulation resistance: ≥100MΩ (500VDC);
 After test: ≥50MΩ
 4. Withstand voltage: 500VAC ;
 5. Insertion and extraction force: 3N~30N;
 6. life test: 5000cycles min;
 7. Operation temperature range: -40℃~105℃;
 8. Preservation temperature range: -40℃~85℃;

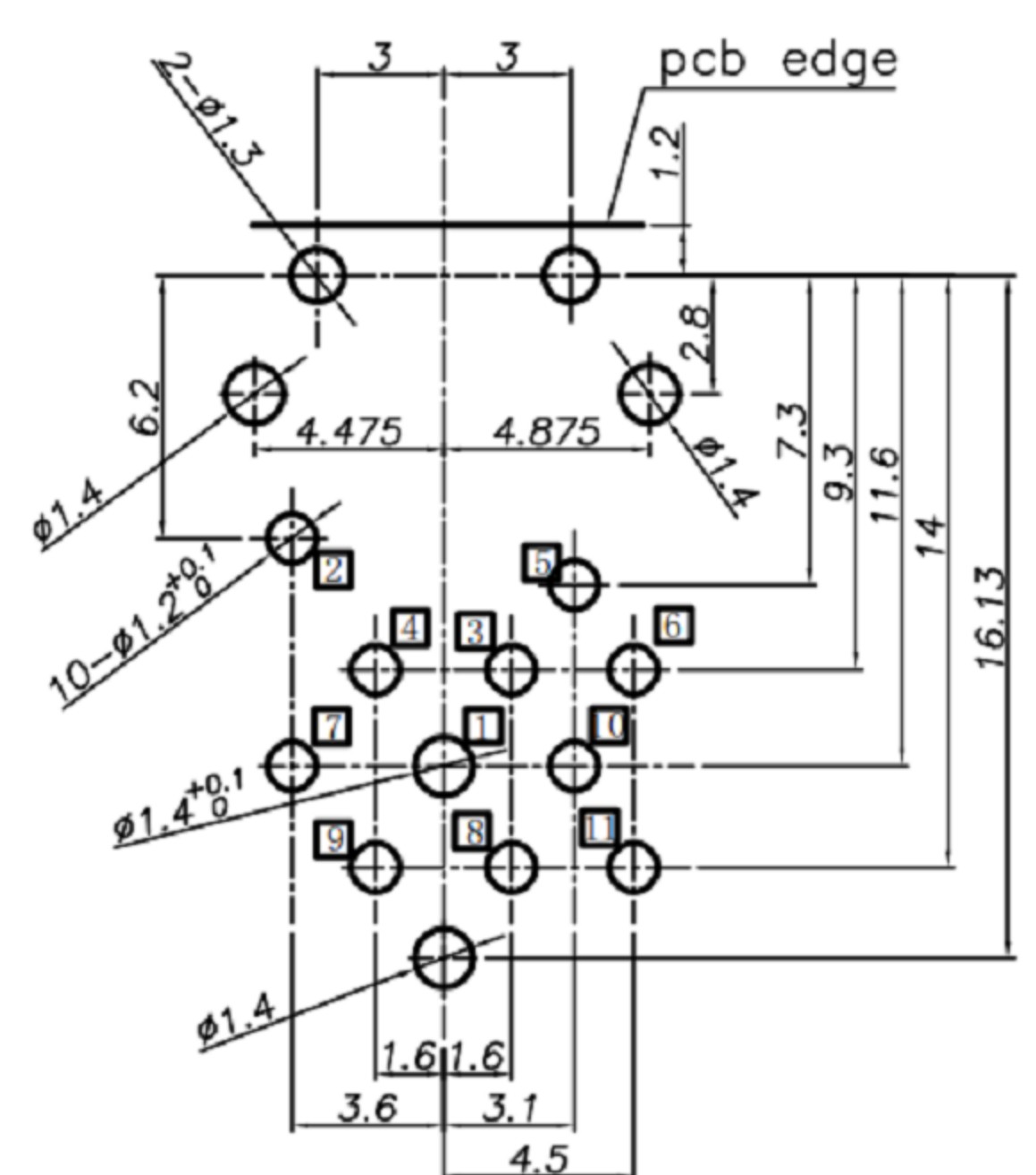
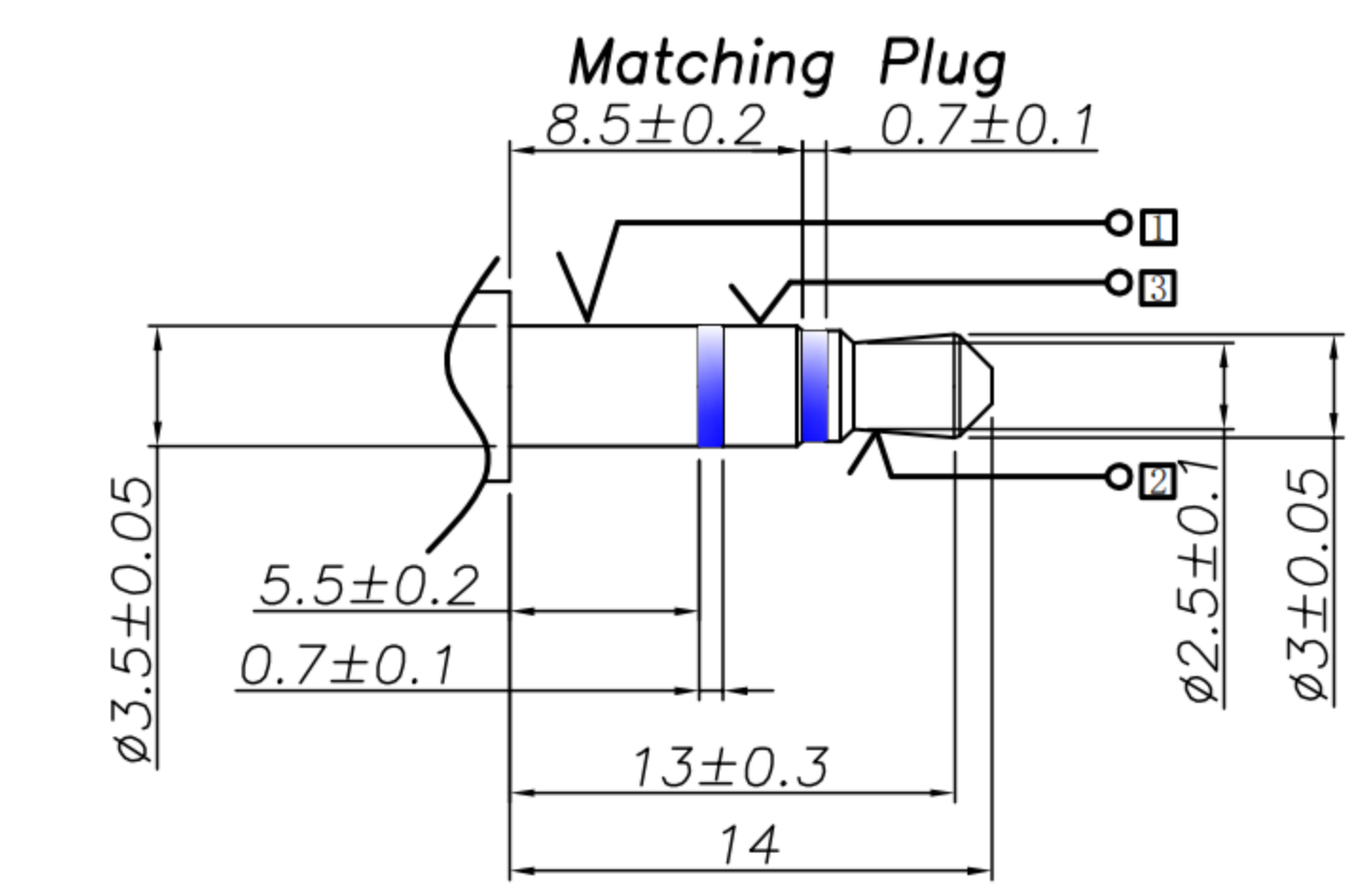
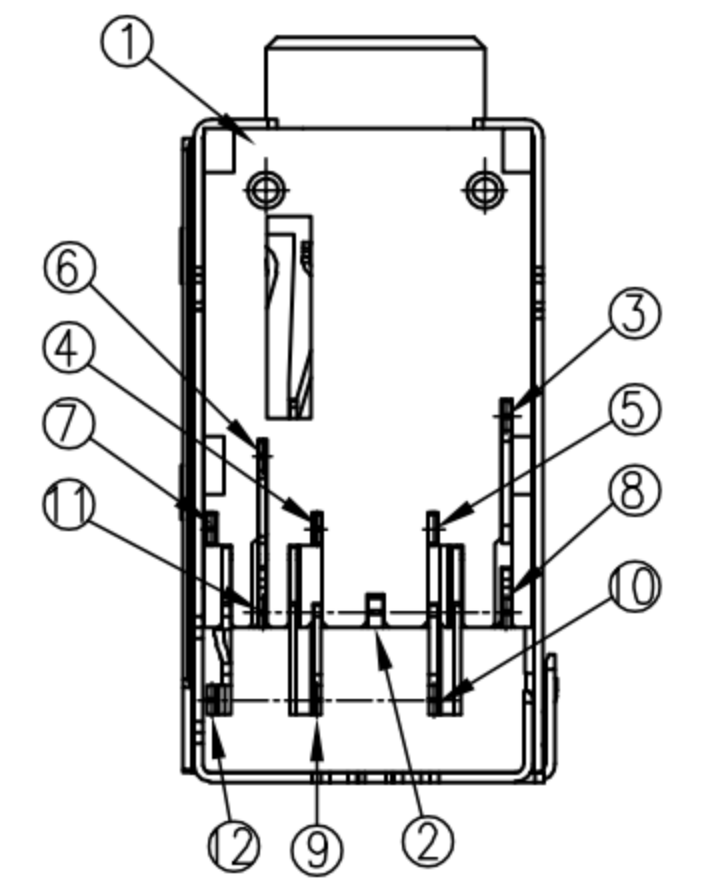
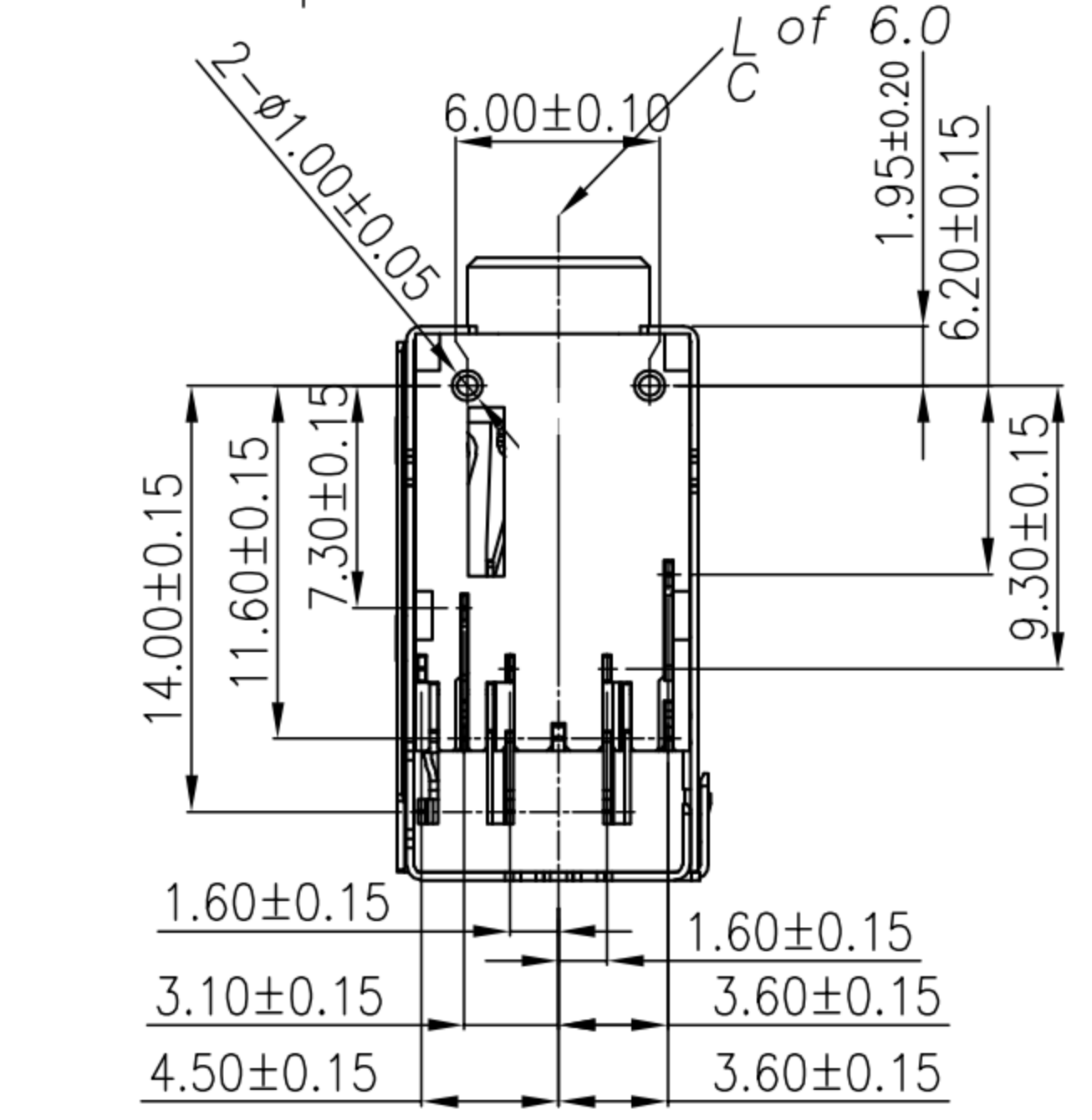

RECOMMENDED P. C. B. LAYOUT
 UNSPECIFIED TOLERANCE: ±0.05 (TOP VIEW)

13	Shell	1	C2680-H, 0.25t	Ni 70u'' Min.
12	Transfer terminal 11	1	C5210-EH, 0.25t	Au 15u''Min./Tin(100u''~200u'')/Ni 70u''Min.
11	Break terminal 10	1	C2680-H, 0.20t	Au 15u''Min./Tin(100u''~200u'')/Ni 70u''Min.
10	Shunt terminal 9	1	C2680-H, 0.25t	Au 15u''Min./Tin(100u''~200u'')/Ni 70u''Min.
9	Ring spring 8	1	C5210-EH, 0.20t	Au 15u''Min./Tin(100u''~200u'')/Ni 70u''Min.
8	Tip spring-2 7	1	C5210-EH, 0.25t	Au 15u''Min./Tin(100u''~200u'')/Ni 70u''Min.
7	Transfer terminal-1 6	1	C5210-EH, 0.25t	Au 15u''Min./Tin(100u''~200u'')/Ni 70u''Min.
6	Break terminal-1 5	1	C2680-H, 0.20t	Au 15u''Min./Tin(100u''~200u'')/Ni 70u''Min.
5	Shunt terminal-1 4	1	C2680-H, 0.25t	Au 15u''Min./Gold flash/Ni 70u''Min. △2
4	Ring spring-1 3	1	C5210-EH, 0.20t	Au 15u''Min./Tin(100u''~200u'')/Ni 70u''Min.
3	Tip spring-1 2	1	C5210-EH, 0.25t	△2 Au 15u''Min./Tin(100u''~200u'')/Ni 70u''Min.
2	Earth spring 1	1	C5191-EH, 0.40t	Au 15u''Min./Tin(100u''~200u'')/Ni 70u''Min.
1	Housing	1	PA10T(R630NH) UL94V-0	
NO.	DESCRIPTION	QTY	MATERIAL	Plating spec

5	新增PLUG標號	Jack	052819
4	更新圖面	Jack	052419
3	新增3d上方圖	Jack	101918
2	更新圖面	Jack	092818
1	新增尺寸	Jack	070717
ITEM NO.	DESCRIPTION	DRAWN	DATE

东莞市高迪电子有限公司
 Dong Guan KDRR Electronic Switch Jack Co., Ltd.

TOLERANCE UNLESS OTHERWISE STATED:
 Up to 5 ±0.2
 Above 5 ~ 15 ±0.3
 Above 15 ~ 30 ±0.4
 Above 30 ~ 50 ±0.5
 Angle ±0.3

3RD. ANGEL'S
 UNITS MM

DRAWN BY:	DATE	MAT'L	TITLE	JACK
Ming Ming Zou	6/8/23			
CHECKED BY:	DATE	FINISH	MODLE	PHONE JACK
Ning Ning Su	6/8/23			
APPROVED BY:	DATE	SCALE	DWG NO.	SIZE
Jia Xiang	6/8/23	1:1		A4
SHEET NO.	1 of 1	PART NO.		VER
				R5